

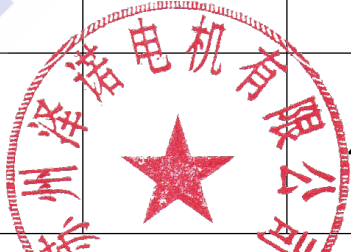

**PRODUCT SPECIFICATION  
APPROVAL SHEET**

产品规格承认书

Customer (客户): \_\_\_\_\_  
Description (规格): AC METAL BLADES AXIAL FAN  
Model No (型号): 25489-AC220HBAMLC  
Sample Issue Date(送样日期): \_\_\_\_\_  
Edition (版本): 2020-08-15

<b>CONFIRMATION SIGNATURE</b> 客户承认栏	<b>ZERO SIGNATURE</b> 泽诺承认栏		
<p>Please confirm your acceptance of this approval sheet by return fax. 本承认书若贵司确认无误后, 请于上方承认栏内签章寄回.</p>	APPD. 核准	EDAM. 审核	DRAW. 制表
	 张婷		

苏州泽诺电机有限公司

SUZHOU ZERO MOTOR CO.,LTD.



Room B20, Building 21, No. 98 Changjiang Road, Wuzhong District,  
Suzhou City, Jiangsu Province, China

Tel:13827275950 GARY E-mail: 1363174347@qq.com / gary@taiwanzero.com

[www.taiwanzero.com](http://www.taiwanzero.com)

**PRODUCT SPECIFICATION  
APPROVAL SHEET**

**产品规格承认书**

一、 Sample Specification(送样规格):

Item(项目)		Specification/Condition(规格/条件)	
01	Part No(型号)	25489-AC220HBAMLC	
02	Outline Dimension(外形尺寸)	φ 254mm*90mm	
03	Rated Voltage(额定电压)	AC 220V	
04	Voltage Range(电压范围)	AC 220V~240V	
05	Frequency(频率)	50/60Hz	
06	Rated Current(额定电流)	0.35A±10%	25°C 60~80%RH
07	Power Consumption(消耗功率)	75W±10%	25°C 60~80%RH
08	Speed(转速)	2600RPM±10%	25°C 60~80%RH
09	Max. Airflow(最大风量)	21.4m <sup>3</sup> /Min±10%	25°C 60~80%RH
10	Max. Static Pressure(最大静压)	0.76Inch-H <sub>2</sub> O	Rated Current(额定电流)
11	Noise Level(噪音)	75dB(A)	
12	Weight (重量)	2150g	

二、 Electrical Specification(电气规格):

Item(项目)		Specification/Condition(规格/条件)
01	Dielectric Strength (绝缘耐压)	1800V/1s/5mA
02	Insulation Resistance (绝缘阻抗)	100 Meg Ohm Min. at 500VDC
03	Motor Protection(电机保护类型)	Thermal Protected
04	Temperature Test of Run (连转温升)	ΔT≤70K Rated Voltage(额定电压)
05	Locked Rotor Protection (锁定检测)	ΔT≤130K Rated Voltage(额定电压)
06	Protection (保护功能)	Automatic Restart Capability

三、 Safety Approvals(安规情况):

Safety Approvals (安规)	File No (安规编号)	Safety Approvals (安规)	File No (安规编号)
CE	XK2104012245C	N/A	N/A
CUL	N/A	N/A	N/A

**苏州泽诺电机有限公司**

**SUZHOU ZERO MOTOR CO.,LTD.**



Room B20, Building 21, No. 98 Changjiang Road, Wuzhong District,  
Suzhou City, Jiangsu Province, China

Tel:13827275950 GARY E-mail: 1363174347@qq.com / gary@taiwanzero.com

[www.taiwanzero.com](http://www.taiwanzero.com)



TUV	N/A	N/A	N/A
TUV-EMC	N/A	N/A	N/A

#### 四、 Environmental Specification(环境条件):

Item(项目)		Specification/Condition(规格/条件)
01	Operating Temp. Range (工作温度/湿度范围)	Temperature/温度: -20°C~70°C Humidity/湿度: 20%~85%RH
02	Storage Temperature (保存温度/湿度范围)	Temperature/温度: -30°C~85°C Humidity/湿度: 20%~95%RH
03	Life (寿命)	40000H (At40°C)

#### 五、 Main Materials/Parts Specification(主要材料/零件规格):

Item(项目)		Specification(规格)
01	Blade(扇叶)	Iron Painted Black
02	Frame(框架)	Aluminum ADC-12,Painted Black
03	Stator& Rotor (定子与转子)	Silicon steel,H-17 & H-17
04	Magnet Wires(漆包线)	QZY-2/180
05	Bobbin(绝缘套)	PA66+30%GF,UL 94 V-0

#### 六、 Outline Dimension(尺寸外观):

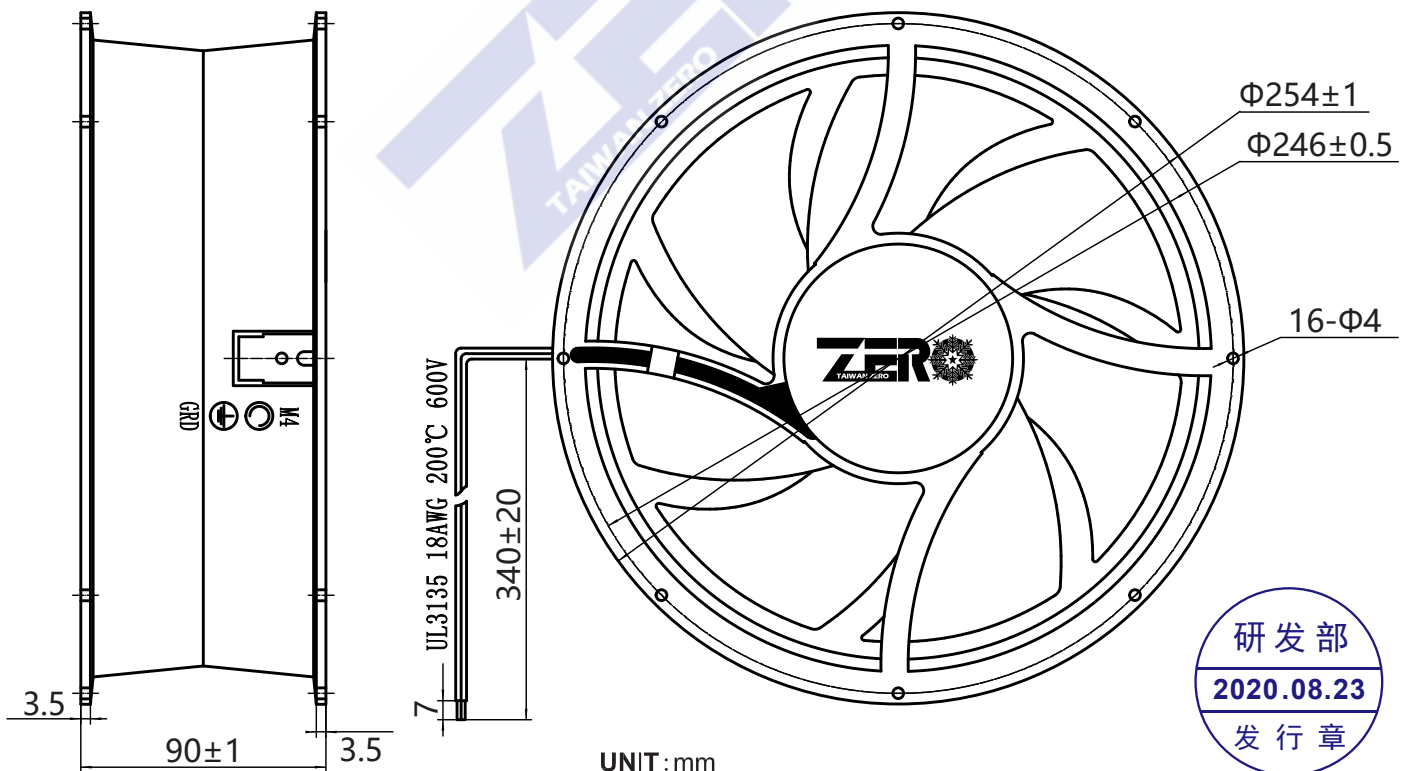

苏州泽诺电机有限公司

SUZHOU ZERO MOTOR CO.,LTD.



Room B20, Building 21, No. 98 Changjiang Road, Wuzhong District,  
Suzhou City, Jiangsu Province, China

Tel:13827275950 GARY E-mail: 1363174347@qq.com / gary@taiwanzero.com

[www.taiwanzero.com](http://www.taiwanzero.com)

七、Property(特性图):

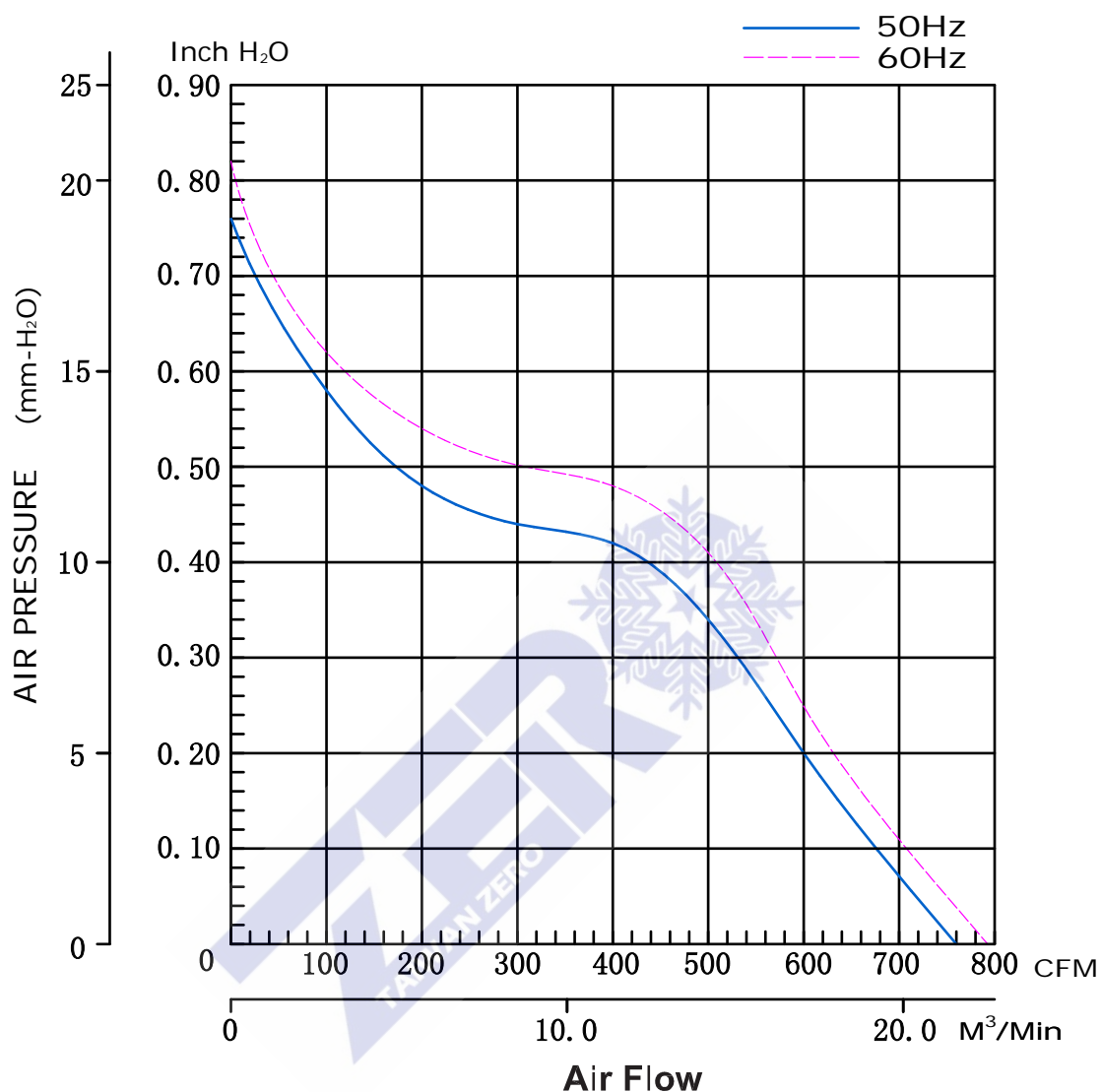

苏州泽诺电机有限公司

SUZHOU ZERO MOTOR CO.,LTD.



Room B20, Building 21, No. 98 Changjiang Road, Wuzhong District, Suzhou City, Jiangsu Province, China

Tel:13827275950 GARY E-mail: 1363174347@qq.com / gary@taiwanzero.com

[www.taiwanzero.com](http://www.taiwanzero.com)